

Creda

Instructions for Installation and Use

**Electric Hob
Model S710E**

To the Installer

Before installation fill in the product details on the back cover of this book.
The information can be found on the rating plate.

To the User

You must read the instructions prior to installing and using the appliance and
then retain them for future reference.

CONTENTS

Introduction	3
For Your Safety	4
Know your Hob	5
How to use your Hob	5
Practical Advice	6
Care and Cleaning	7
Troubleshooting	7
Installation	8
Electrical Connection	9
Key Contacts	Back Cover

Retention of this Instruction Book

This Instruction Book must be kept handy for reference as it contains important details on the safe and proper use of the appliance.

If you sell or pass the appliance to someone else, or move house and leave it behind, make sure this Book is also provided so the new owner can become familiar with the appliance and safety warnings.

If the Book is lost or damaged a copy may be obtained from:
GDA LTD., Morley Way, Peterborough, PE2 9JB

Introduction

Your new hob is guaranteed* and will give lasting service. This guarantee is only applicable if the appliance has been installed in accordance with the installation instructions detailed in this booklet.

To help make best use of your cooking equipment, please read this booklet carefully.

The hob is designed specifically for domestic use and responsibility will not be accepted for use in any other installation.

When first using the hob, ensure that the room is well ventilated (eg. open a window or use an extractor fan) and that persons who may be sensitive to the odour avoid any fumes. It is suggested that any pets be removed from the room until the odour has ceased. This odour is due to temporary finish on elements.

Before using the hotplates for the first time, we recommend you heat them at maximum temperature for approximately 4 minutes (without pans). During this initial stage, their protective coating hardens and reaches its maximum resistance.

*** The guarantee is subject to the provisions that the appliance:**

- (a) Has been used solely in accordance with this booklet.**
- (b) Has been properly connected to a suitable supply voltage as stated on the rating plate, attached to the appliance.**
- (c) Has not been subjected to misuse or accident or been modified or repaired by any person other than the manufacturers authorised employee or agent.**
- (d) Has been correctly installed.**



This appliance conforms with the following European Economic Community directives

- 73/23/EEC of 19/02/73 (Low Voltage) and subsequent modifications.
- 89/336/EEC of 03/05/89 (Electromagnetic Compatibility) and subsequent modifications.
- 93/68/EEC of 22/07/93 and subsequent modifications.

For Your Safety

When used properly your appliance is completely safe but as with any electrical product there are certain precautions that must be observed.

PLEASE READ THE BELOW PRECAUTIONS BEFORE USING YOUR APPLIANCE.

To maintain the efficiency and safety of this appliance, we recommend you do the following:

- only call the Service Centres authorised by the manufacturer.
- always use genuine spare parts.

ALWAYS:

- make sure you remove all packaging and dispose of safely.
- check the soundness of the appliance after it has been unpacked.
- make sure you understand the controls before using the appliance.
- keep children away from the appliance during use.
- take care to avoid heat/steam burns when operating the controls.
- make sure the controls are turned off when you have finished cooking and when not in use.
- disconnect from the power supply, and allow to cool, before cleaning or performing maintenance.
- refer servicing to a qualified appliance service engineer.
- keep the hob clean as a build up of grease or fat from cooking can cause a fire.
- follow the basic principles of food handling and hygiene to prevent the possibility of bacterial growth.
- dry food thoroughly before frying and lower it slowly into the hot oil or fat. Frozen food in particular, will cause frothing and spitting if added too quickly.
- keep outside of pans clean and free from streaks of oil or fat.
- place pans centrally over the hotplates making sure handles are kept away from the edge of the hob and cannot be heated by other hotplates/pans.
- keep any ventilation slots clear of obstructions.

NEVER:

- attempt to install or repair the appliance without the assistance of qualified personnel.
- store items above the appliance that children may attempt to reach.
- heat up unopened food containers, as pressure can build up causing the container to burst.
- use the appliance to heat up anything other than food.
- use the appliance as a room heater.
- dry any items on the hob.
- install the appliance next to curtains or other soft furnishings.
- allow children to play with or tamper with the controls.
- leave children unsupervised where cooking appliances are installed as all the cooking surfaces get hot during and after use.
- store chemicals, foodstuffs or pressurised containers in or on the appliance, or in cabinets immediately above or next to the appliance.
- use flammable or plastic items on or near the hob.
- use adapters, multiple sockets and/or extension leads.
- fill a deep fat frying pan more than 1/3 full of oil, or use a lid. **DO NOT LEAVE UNATTENDED WHILE COOKING.**
- fry too much food at a time, especially frozen food. This only lowers the temperature of the oil or fat too much, resulting in greasy food.
- pull on the appliance or the supply cable to unplug it from the electrical outlet.
- allow power cables of other appliances to come into contact with hot parts of this appliance.
- expose the appliance to atmospheric agents, such as rain or sunlight.
- operate the appliance with wet hands.
- operate the appliance when barefoot.
- allow anyone to sit or stand on any part of the appliance.
- use misshapen pans which may be unstable.
- use fish kettles or large preserving pans across two hotplates.
- leave anything on the hob surface when unattended and not in use.

SAFETY ADVICE

IMPORTANT - As with any cooking appliance there could be some fire risk attached to the heating of oil, particularly for deep fat frying. Cooking utensils containing oil must not be left unattended (eg. to answer the telephone) on or in close proximity to the cooking areas.

IN THE EVENT OF A CHIP PAN OR ANY OTHER PAN FIRE:

1. Turn off the hotplates.
2. Cover the pan with a fire blanket or damp cloth, this will smother the flames and extinguish the fire.
3. Leave the pan to cool for at least 60 minutes before moving it. Injuries are often caused by picking up a hot pan and rushing outside with it.

NEVER USE A FIRE EXTINGUISHER TO PUT OUT A PAN FIRE as the force of the extinguisher is likely to tip the pan over. Never use water to extinguish oil or fat fires.

Know your Hob

- A Electric plate
- B Control knobs for the electric hotplates
- C Pilot light of the electric plates

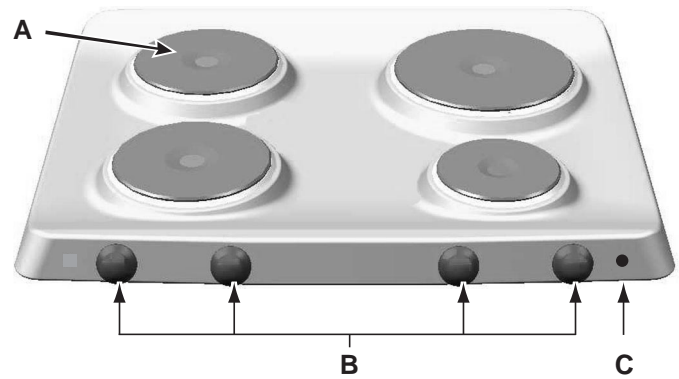

How To Use Your Hob

The position of the corresponding electric hot plate is indicated on each control knob.

Electric Hotplates

The hot plates vary in diameter and power: "normal" and "fast". The latter can be identified by a red spot in the centre of the hot plate itself.

The hot plate can be regulated by turning the corresponding knob in the clockwise or counter-clockwise direction to any one of the 6 different settings:

- 0 Off
- 1 Low
- 2-5 Medium
- 6 High

The section entitled, "Practical Advice", provides information on the recommended settings for various types of food or cooking processes.

When the knob is on any of the settings other than "Off", the "C" pilot light comes on.

Practical Advice

Choice of utensils:

Every Electric Hob deserves the right choice of utensils. We recommend for optimum performance the use of good quality utensils.

PANS SHOULD NOT:

- Be concave (bowed in).
- Be convex (bowed out).
- Be rimmed.
- Be deeply ridged.

BUT SHOULD BE ESSENTIALLY FLAT

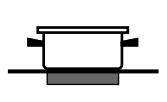
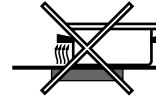
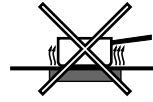
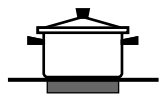
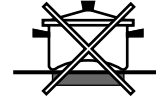
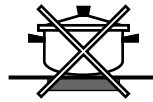

Always

- Use good quality flat-based cookware on all electric heat sources.
- Place pans centrally on the hotplate.
- Ensure pans have clean, dry bases before use.
- Ensure pans match the size of the heating area.
- Remember good quality pans retain heat well, so generally only a low or medium heat is necessary.
- Ensure pan handles are positioned safely and away from heat sources.
- Lift pans, do not drag.
- Use pan lids, except when frying.
- Deal with spillage immediately, but with care.

Never

- Use gauze, metal pan diffusers, asbestos mats and stands eg. wok stands - they can cause overheating.
- Use utensils with skirts or rims eg. buckets and some kettles.
- Use badly dented or distorted pans.
- Leave an element on when not cooking.
- Cook food directly on the hotplate.
- Drag or slide utensils across the hotplate.
- Place large preserving pans or fish kettles across two hotplates.
- Place plastic vessels or utensils on a hot hob.
- Use the hob as an area for storage.

In order to avoid heat loss and damage to the hotplate, use utensils with a flat bottom the diameter of which is not less than that of the hotplate.

Setting	Normal or Fast Plate
0	Off
1	Cooking vegetable, fish
2	Cooking potatoes (using steam), soups, chickpeas, beans
3	Continuing the cooking of large quantities of food, minestrone
4	For roasting (average)
5	For roasting (above average)
6	For browning and reaching boil in a short time

Care and Cleaning

Before cleaning or performing maintenance on your hob, disconnect it from the power supply. Check that all controls are in the OFF position before reconnecting.

Clean spills immediately.

NEVER USE: Washing powder, harsh abrasive, scouring pads, aerosol cleaners or oven chemical cleaners of any kind.

Cleaning materials to avoid

- Household abrasive powders, eg. Vim.
- Oven chemical cleaners, aerosols and oven pads - Caustic cleaners such as these will etch the surface and attack the metal frame.
- Bath and sink cleaners may mark the surface.

The Hotplates

Clean with a cloth wrung out in warm water. Then rub a little cooking oil into the hotplates while they are still warm to condition the surface. Ensure care is taken as the hotplates will be warm.

Enamelled, Stainless Steel and Glass parts

Wipe with a cloth wrung out in warm soapy water followed by a wipe with a cloth wrung out in clean water and then dry with a soft clean cloth.

Control Knobs

Wipe over the knobs with a soft cloth wrung out in warm soapy water or mild non-abrasive. Then, after wiping with a cloth wrung out in clear water, dry with a soft clean cloth.

Painted Metal Surround Trim

Wipe over with a cloth wrung out in warm soapy water only. **DO NOT USE ABRASIVES.**

Troubleshooting

Before calling service for assistance, check through the following list, there may be nothing wrong.

Nothing works.

Check to make sure that:

- the mains wall switch is switched on.

Hotplates are slow to boil or will not simmer.

Check to make sure that:

- Your pans conform with the recommendations detailed in this book.

If, despite all of these checks, the hob does not function properly and problem persists, call Hotpoint Service (see KEY CONTACTS, back page), informing them of:

- The type of problem.
- The abbreviation used to identify the model (Mod. ...) as indicated on the warranty.

IMPORTANT:

Never call upon technicians not authorized by the manufacturer, and refuse to accept spare parts that are not original.

Installation

The following instructions are intended for a qualified installer so that the installation and maintenance procedures may be followed in the most professional and expert manner possible.

Important: Unplug the electrical connection before performing any maintenance or regulation upkeep work.

Installation of built-in hobs

The electric hobs are prepared with protection degree against excessive heating of Y type, it is therefore possible to instal them next to furniture which is higher than the worktop. For a correct installation of the hob the following precautions must be followed:

- The hob may be located in a kitchen, a kitchen/diner or bed sitting room, but not in a bathroom or shower room.
- The hoods must be installed according to the requirements in the hood handbook.
- The dimensions of the cutout for the appliance must be those indicated in the figure. Clamps are provided to fasten the hob to worktops measuring from 20 to 40 mm in thickness. To fasten the hob securely, it is recommended that all the clamps be used.

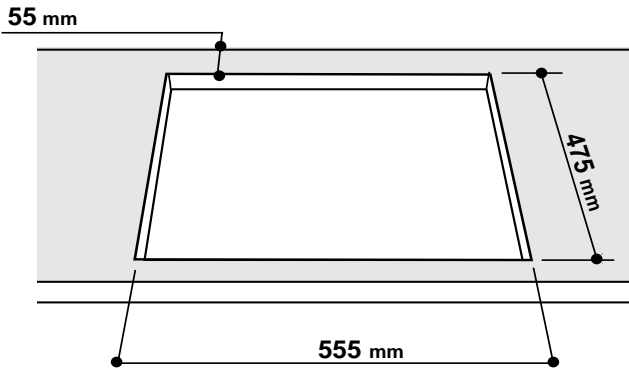

Fastening Clamps - Assembly Diagram

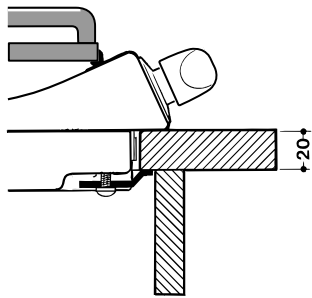

Clamp Position for
H=20mm top

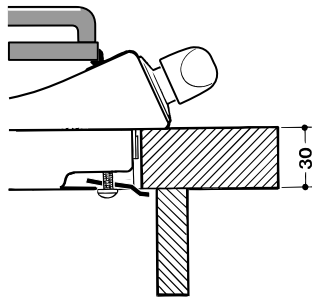

Clamp Position for
H=30mm top
Front

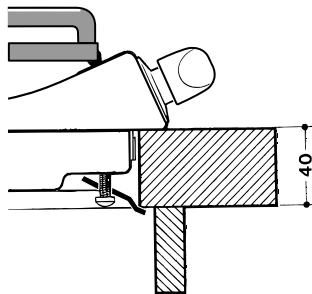

Clamp Position for
H=40mm top

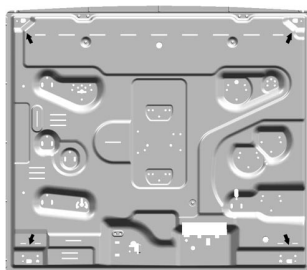

Back

N.B: Use the clamps contained in the "accessory kit."

d) In case a wooden panel should be fitted under the top for insulation, it will have to be fitted at a minimum distance of 20 mm from the inferior part of the top.

Important: When installing the hob on a built-in oven, the oven should be placed on two wooden strips; in the case of a joining cabinet surface, remember to leave a space of at least 45 x 560 mm at the back.

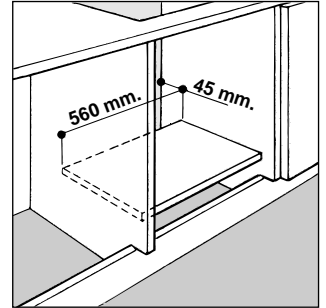
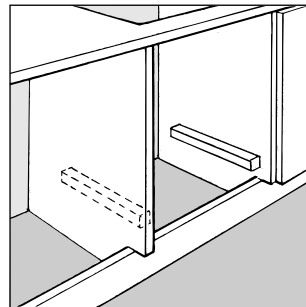

When installing on a built-in oven without forced ventilation, ensure that there are air inlets and outlets for ventilating the interior of the cabinet adequately. Assembly examples are given in figs.

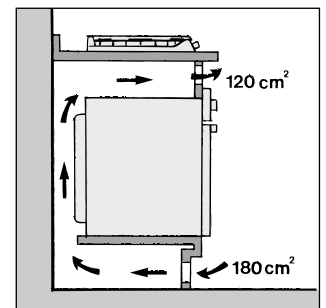
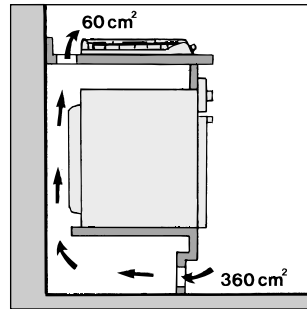

Electrical Connection

Supply cable installation

The electric hobs are supplied without cable. Use a cable:
H05 VV-F 3x2.5mm²

- Open the terminal box by removing the "V" screw and taking off the cover.
- The wires in the mains lead are coloured in accordance with the following code:

Green & Yellow - Earth "E" 
Blue - Neutral "N"
Brown - Live "L"

Connect the wires in accordance with the following diagram

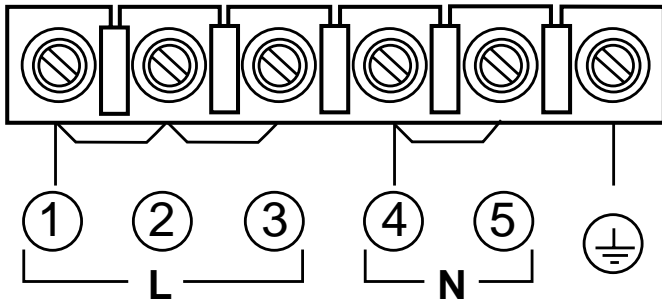

- Fix the cable in place with the "F" cable clamp, close the lid and fasten it with the "V" screw.

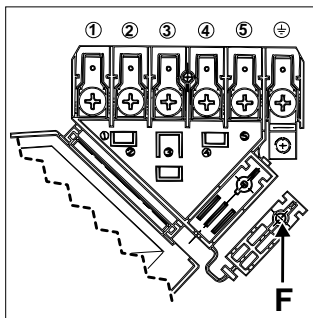
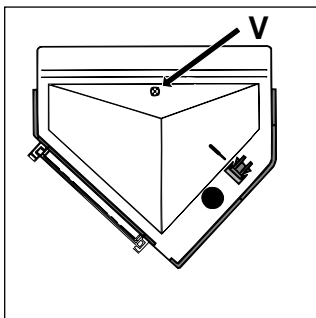

Connecting the supply cord to the electrical mains:

The hob must be connected to the mains by a double pole mains switch, which must have a minimum of 3mm space between the contacts, correctly fused with a capacity appropriate to that shown on the hob Rating Plate. All electrical wiring from the consumer unit to the appliance, via the switched double pole cooker outlet, must be of an acceptable type and current rating as above.

The supply cord should conform to BS6004 conductor size 4mm², must be positioned so that no part of it reaches a temperature of 50°C above room temperature. The electrical installation must comply with the IEE Regulations, Building Regulation & local By-Laws.

Before making the connection, make sure that:

- the limiter switch (fuse) and the residual wiring can support the appliance load (see the rating plate).
- the mains system is properly earthed in compliance with current regulations and provisions.
- there is easy access to the socket or the double pole switch after the appliance is installed.

IMPORTANT:

If the hob is installed above a built-in oven, the electrical connection for the hob must be independent of that for the oven, both for safety reasons and to facilitate the removal of the oven for maintenance, repair etc.

Voltage and frequency of power supply:

240V ~ 50/60Hz 5600W

Creda

Key Contacts

After Sales Service

Over 1200 trained specialists, directly employed by us, ensure that you can have complete confidence in both the appliances and services we offer.



Repair Service and Information Desk

UK: 08709 066 066

(Open 8 to 8 Mon - Fri, 8 to 6 Sat, 10 to 4 Sun & Bank Holidays)

www.theservicecentre.co.uk

Republic of Ireland: 1850 302 200

Note: Our operators will require the following information:

Model number:

Serial number:

Extended Warranties

UK: 08709 088 088

(Open 8 to 8 Mon - Sun)

www.theservicecentre.co.uk

Republic of Ireland: 1850 502 200

Genuine Parts and Accessories

UK: 08709 077 077

(Open 8-30 to 5-30 Mon - Fri & 9 to 12 Sat)

www.theservicecentre.co.uk

Republic of Ireland: (01) 842 6836